



BS EN877 EPOXY CAST IRON PIPES & FITTINGS FOR DRAINAGE SYSTEM



仲賢行有限公司
CYH Limited

Office : Unit 1203, 12/F., Austin Tower, 22-26 Austin Avenue, TST., Kln., H.K.
寫字樓 : 香港九龍尖沙咀柯士甸路22-26號好兆年行12樓1203室
電話 : (852) 2967 3999 傳真 : (852) 2818 6890
旺角舖門市 : 九龍旺角上海街687號地下 電話 : (852) 2390 2188
荃灣舖門市 : 新界荃灣德華街18號德範樓地下 電話 : (852) 2882 8281



YU KUNYU BS EN877 EPOXY CAST IRON PIPES & FITTINGS FOR DRAINAGE SYSTEM

About Wuan City Kun Yu Metal Products Co., Ltd

Wuan City Kun Yu Metal Products Co., Ltd. Is a professional manufacturer of cast-iron drainage pipes and sets up in 2006, the enterprise covers a total area of 70,000 square meters, with an annual output of 20,000 tons of cast-iron drainage pipes and 10,000 tons of cast-iron pipe fittings.

Kun Yu factory has advanced production equipment and complete testing methods. The whole process is controlled strictly by inspection, so that the products can meet the standard requirements in chemical composition, mechanical properties, organization, hydraulic test, and other aspects, providing a reliable guarantee for the excellent quality of the products. The company adheres to the quality policy of sustainable development to create a green factory, in which "Quality is the basis of reputation, Technology, and Management are the basis of efficiency." and conscientiously implements the ISO9001 quality management system standards. The product quality has reached the advanced level of ISO6594, BS EN877, ASTMA888, GB/T12772, KSD4307, and multinational advanced level, exported to Hong Kong, United Kingdom, Germany, Russia, Norway, Sweden, and other regions.

At present, the main products of the Kun Yu factory are cast iron pipes and fittings. The drainage cast iron pipes are produced by centrifugal casting with the hot mold method, special internal and external surface treatment, epoxy resin anti-corrosion coating, high-temperature drying coating, and other advanced technologies.

The company has 15 centrifuge casting machines, 2 shot blasting machines, 2 sets of automatic cutting internal grinding machines, 7 sets of pipe grinding machines, more than 1500 kinds of pipe fitting molds, and a set of automatic horizontal production lines.

Quality testing equipment: tensile test machine, hardness test machine, carbon, and sulfur analyzer, and two sets of cold and hot water circulation equipment. The product has the characteristic of high strength and lightweight, and the installation is very convenient, thus can greatly accelerate the construction schedule; The product has a thin wall, uniform, smooth inside and outside; Dense structure, no leakage, corrosion resistance, anti-seismic, anti-noise, high-temperature resistance, simple construction and maintenance, reliable installation, long durability, and other advantages.

Wuan City Kun Yu Metal Products Co., Ltd. always adheres to the "sincere to the world's customers, cast a global quality pipe" business purpose, dedicated to service and cooperating with domestic and foreign merchants.



YU KUNYU BS EN877 EPOXY CAST IRON PIPES & FITTINGS FOR DRAINAGE SYSTEM

關於武安市坤鈺金屬製品有限公司

武安市坤鈺金屬製品有限公司，是專業生產鑄鐵排水管的企業。企業 2006 年建廠，總佔地面積 70,000 平方米，年產量鑄鐵排水管 20,000 噸、鑄鐵管件 10,000 噸，目前公司已擁有一批高技術、高素質、高服務的精銳團隊。

廠生產設備先進，檢測方法齊全。通過檢測進行嚴格的工序控制，使產品在化學成分、機械性能、水壓試驗等各方面均達到標準要求，為出廠產品的優良質量提供了可靠的保證。公司堅持“質量是信譽之基，技術和管理是效益之本。”的持續發展的質量方針，認真貫徹 ISO9001 質量管理體系標準之基、創建綠色工廠。產品質量均達到 ISO6594、BS EN877、ASTMA888、GB/T12772、KSD4307 等多國先進水平，出口香港、英國、德國、俄羅斯、挪威、瑞典等地區

目前廠的經營產品主要為鑄鐵管和鑄鐵管件，生產的排水鑄鐵管採用了離心鑄造特殊的內外表面處理，環氧樹脂防腐層、高溫烘乾塗裝等先進工藝。公司現有離心機 15 台，拋丸機 2 台、自動切割內磨機 2 套，磨管機 7 台，管件模具達到 1500 多種，一整套自動水平生產線，質量檢測設備：光譜分析儀、耐鹽霧試驗機、測試拉力實驗機、硬度實驗機、碳硫分析儀，冷熱水循環設備兩套。產品具有強度高重量輕的特點，安裝極為方便，因而可以大大加快施工進度；該產品具有壁薄、均勻、內外光滑；組織緻密，無滲漏、耐腐蝕、抗震、防噪音、耐高溫，施工及維護簡便，安裝可靠，耐久性長等優點。

武安市坤鈺金屬製品有限公司始終堅持“誠交天下四海客，鑄出全球精品管”的經營宗旨，竭誠為國內外客商服務與合作。





YU KUNYU BS EN877 EPOXY CAST IRON PIPES & FITTINGS FOR DRAINAGE SYSTEM

Manufacturing and Inspection Procedure

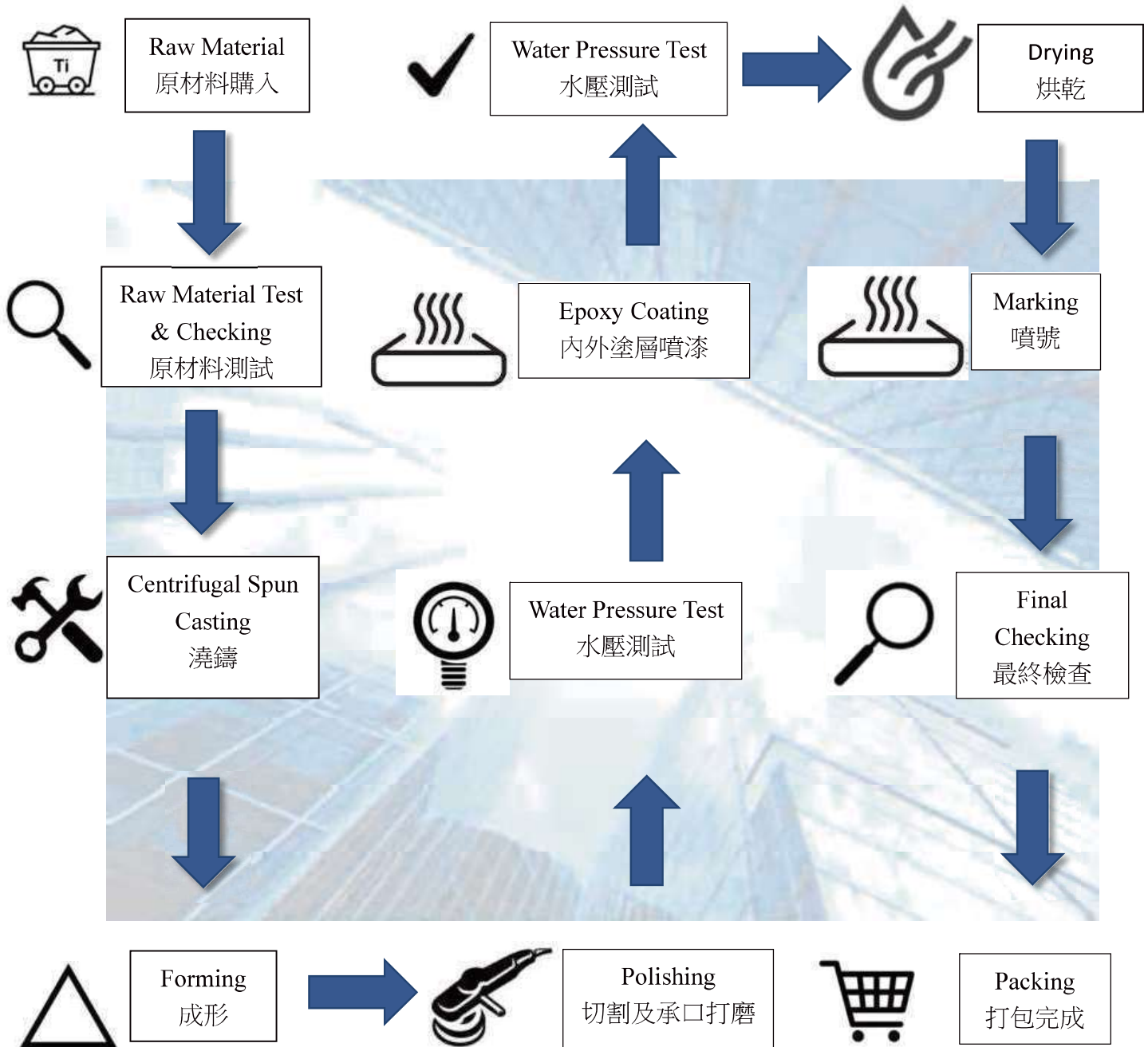



YU KUNYU BS EN877 EPOXY CAST IRON PIPES & FITTINGS FOR DRAINAGE SYSTEM

Advantages of Product

低噪音 Superior Noise Suppression

不易燃 Fire Resistance

耐用 Longevity

容易安裝 Easy to Assemble, Install.

不易變形 Low Thermal Expansion Rates



Certificates





YU KUNYU BS EN877 EPOXY CAST IRON PIPES & FITTINGS FOR DRAINAGE SYSTEM

PIPE

Nominal Size (mm)	Size (Inch)	Outside Diameter D(mm)	Wall thickness T (mm)		Length (mm)
			Nominal Value	Minimum Value	
40	1-1/2"	48	3.00	2.50	3,000
50	2"	58	3.50	3.00	
75	3"	83	3.50	3.00	
100	4"	110	3.50	3.00	
150	6"	160	4.00	3.50	
200	8"	210	5.00	4.00	
250	10"	274	5.50	4.50	
300	12"	326	6.00	5.00	



Body Marking:

YU KUNYU SML BSEN877 A2-s1, d0 (DN) x (Length)

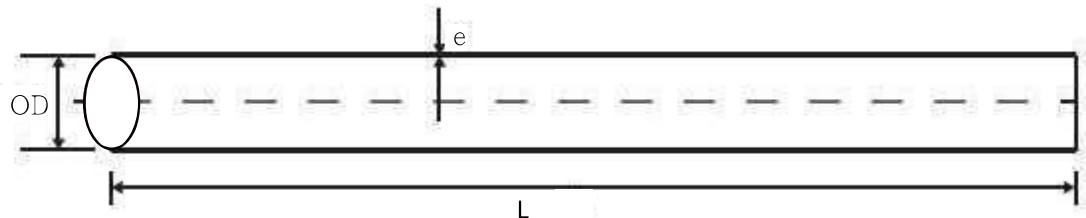



YU KUNYU BS EN877 EPOXY CAST IRON PIPES & FITTINGS FOR DRAINAGE SYSTEM

Fitting

15° BEND		
Nominal Size(mm)	kg/pcs.	X (mm)
50	0.5	35
75	0.8	45
100	1.1	50
150	2.5	65

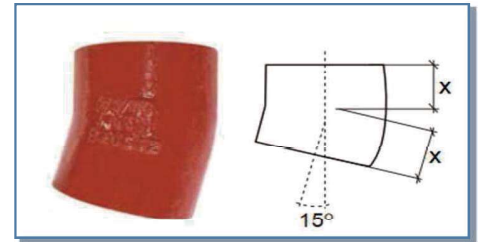

22° BEND		
Nominal Size(mm)	kg/pcs.	X (mm)
50	0.5	45
100	1.3	54
150	3.2	70

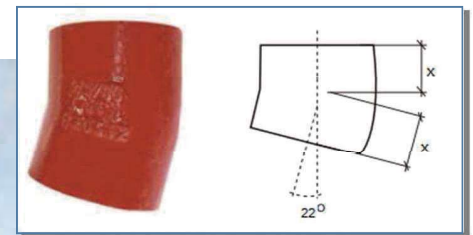

30° BEND		
Nominal Size(mm)	kg/pcs.	X (mm)
50	0.5	45
75	0.8	60
100	1.3	60
150	3.0	80
200	5.6	95

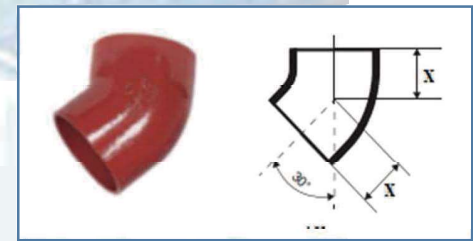

45° BEND		
Nominal Size(mm)	kg/pcs.	X (mm)
50	0.5	50
75	1.0	60
100	1.5	70
150	3.5	90
200	6.3	110
250	10.3	130
300	17.3	155

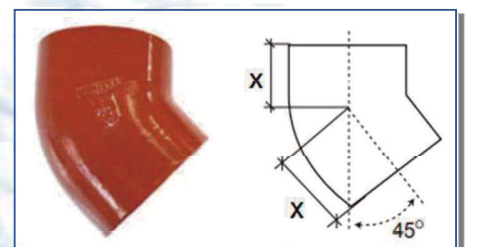

88° BEND		
Nominal Size(mm)	kg/pcs.	X (mm)
50	0.7	75
75	1.0	95
100	1.5	110
150	3.5	145
200	6.3	180
250	10.7	222
300	17.3	263

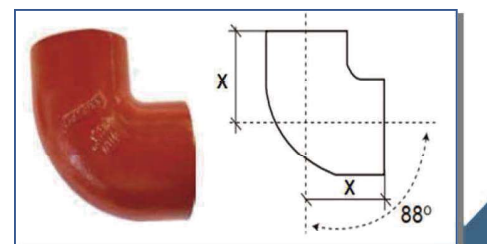



YU KUNYU BS EN877 EPOXY CAST IRON PIPES & FITTINGS FOR DRAINAGE SYSTEM

45° BEND WITH ACCESS DOOR

Nominal Size(mm)	kg/pcs.	A(mm)
50	1.0	60
75	1.7	76
100	2.6	83
150	7.0	113
200	9.0	124
250	20.4	162
300	39.8	207

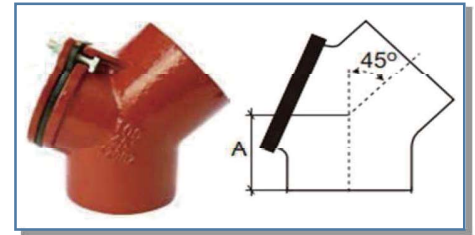

88° BEND WITH ACCESS DOOR

Nominal Size(mm)	kg/pcs.	A(mm)
50	1.1	76
75	2.2	95
100	3.4	110
150	7.0	150
200	13.5	182
250	26.3	222
300	33.5	263

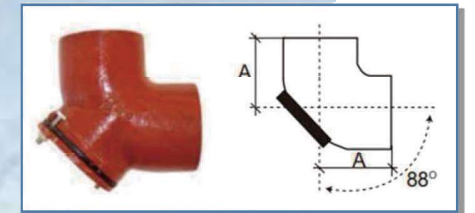

88° DOUBLE ACCESS BEND

Nominal Size(mm)	kg/pcs.	A(mm)	B(mm)	C(mm)
50	1.2	20	100	121
75	1.8	60	120	145
100	3.2	70	140	170
150	7.0	90	180	219

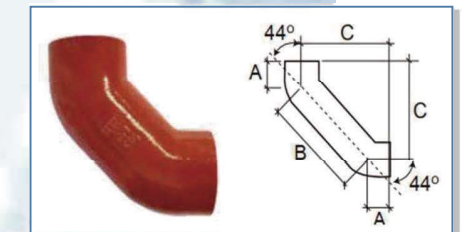

88° VENT BEND

Nominal Size(mm)	kg/pcs.	A(mm)	B(mm)
100 x 50	2.5	111	111

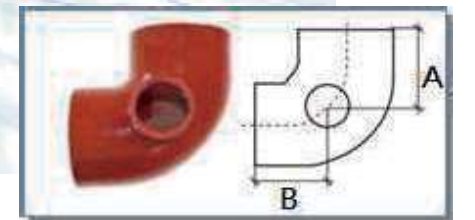

88° LONG RADIUS BEND

Nominal Size(mm)	kg/pcs.	A (mm)	R (mm)
75	3.6	288	250
100	5.4	272	230
100	7.5	434	400
150	9.8	277	230
150	19.5	635	600
200	19.5	350	300
200	23	460	400

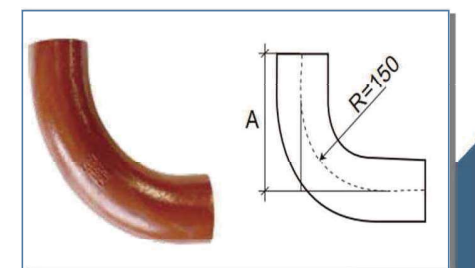



YU KUNYU BS EN877 EPOXY CAST IRON PIPES & FITTINGS FOR DRAINAGE SYSTEM

88° LONG RADIUS BEND ACCESS DOOR

Nominal Size(mm)	kg/pcs.	A	R
100	7	252	150
100	9.5	479	450
150	21.5	635	600
200	22.5	340	300
200	23	446	400
200	35	645	600
250	49	558	500
250	51	655	600
300	75	666	600

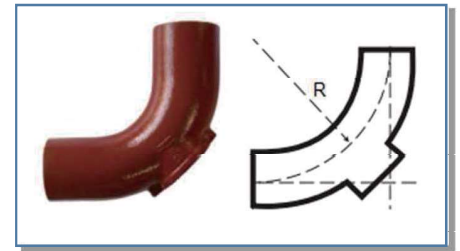

88 Bend with Foot Branch

Nominal Size(mm)	kg/pcs.	a	b	c
100 x 50	2.5	203	110	110

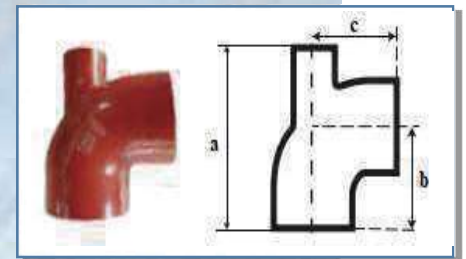

45° DOUBLE BRANCH

Nominal Size(mm)	kg/pcs.	L(mm)	A(mm)	B(mm)
100 x 50	2.7	204	167	167
100 x 100	5.3	263	192	192
150 x 100	9.0	298	242	242
150 x 150	10.8	358	269	269

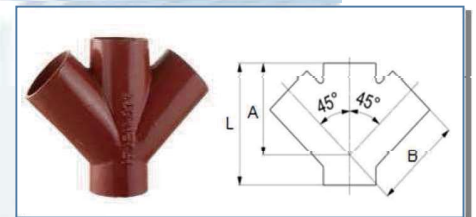

88° DOUBLE BRANCH

Nominal Size(mm)	kg/pcs.	L(mm)	A(mm)	B(mm)	C(mm)
100x50	2.2	183	102	81	107
100x100	3.4	345	178	167	122
150x100	7.1	400	208	192	147

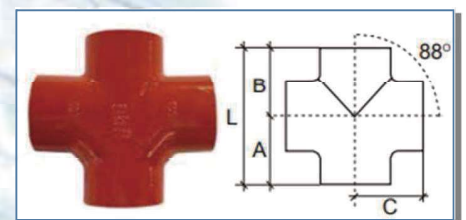

88° Double Corner Branch

Nominal Size(mm)	kg/pcs.	L(mm)	A(mm)	B(mm)	C(mm)
100 x 100	3.4	220	105	115	120
150 x 100	7.1	245	115	130	145

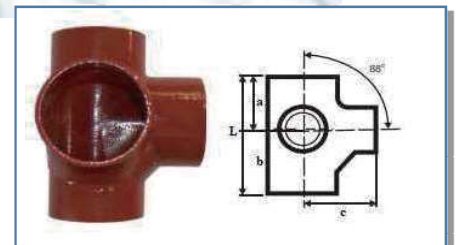



YU KUNYU BS EN877 EPOXY CAST IRON PIPES & FITTINGS FOR DRAINAGE SYSTEM

45° SINGLE BRANCH

Nominal Size(mm)	kg/pcs.	L(mm)	A(mm)	B(mm)	C(mm)
50 x 50	1.4	188	51	137	137
75 x 50	1.8	192	51	141	141
75 x 75	2.4	228	66	162	162
100 x 50	2.5	204	37	167	167
100 x 75	3.1	233	51	182	182
100 x 100	4.2	278	70	208	208
150 x 50	5.5	283	41	242	242
150 x 75	5.9	258	40	218	218
150 x 100	6.8	299	56	243	243
150 x 150	9.2	359	91	268	268
200 x 75	8.3	262	20	242	242
200 x 100	10.0	307	40	267	267
200 x 150	13.3	379	76	303	303
200 x 200	17.2	460	117	343	343
250 x 100	15.4	328	15	313	313
250 x 150	20.2	409	56	353	353
250 x 200	25.1	480	91	389	389
250 x 250	31.5	566	132	434	434
300 x 150	26.9	419	35	384	384
300 x 200	34.0	485	70	415	440
300 x 300	48.2	667	157	510	510

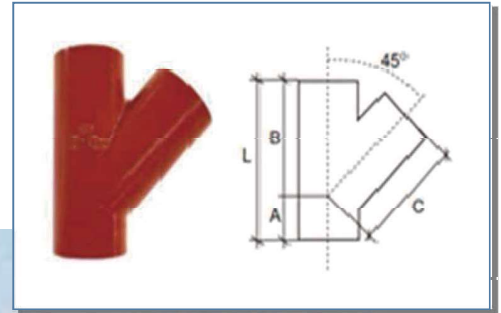

45° INSPECTION BRANCH

Nominal Size(mm)	kg/pcs.	L(mm)	A(mm)	B(mm)	C(mm)
75 x 75	3.0	229	66	163	163
100 x 50	3.6	214	41	173	158
100 x 75	4.5	264	67	197	200
100 x 100	5.3	275	70	205	206
150 x 100	8.0	285	47	238	230
150 x 150	10.4	356	88	268	267
200 x 100	11.0	346	40	306	304
200 x 150	14.0	395	55	340	389
200 x 200	16.4	488	112	376	370
250 x 250	40.0	588	135	453	452
300 x 300	57.2	694	156	538	528

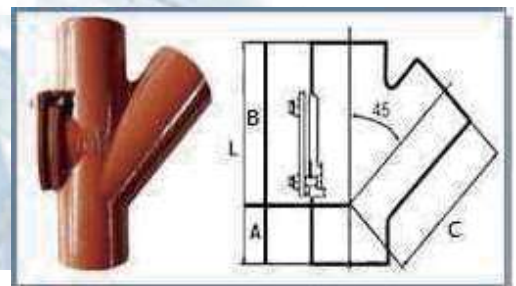



YU KUNYU BS EN877 EPOXY CAST IRON PIPES & FITTINGS FOR DRAINAGE SYSTEM

88° SINGLE BRANCH					
Nominal Size(mm)	kg/pcs.	L(mm)	A(mm)	B(mm)	C(mm)
50 x 50	0.9	146	80	66	81
75 x 50	1.6	155	90	85	91
75 x 75	1.9	183	96	87	95
100 x 50	2.1	174	96	78	107
100 x 75	2.6	193	106	87	112
100 x 100	2.9	223	116	107	122
150 x 50	4.4	203	95	108	142
150 x 75	5.0	223	117	106	142
150 x 100	5.5	247	116	131	146
150 x 150	6.9	302	143	159	156
200 x 100	7.8	271	129	142	175
200 x 150	10.8	329	154	175	154
200 x 200	12.8	379	197	182	190
250 x 100	14.0	311	149	162	148
250 x 150	15.0	359	188	171	189
250 x 200	17.5	408	211	197	235
250 x 250	27.0	473	243	230	246
300 x 100	22.0	348	164	184	185
300 x 150	22.8	404	212	192	258
300 x 200	27.0	455	235	220	265
300 x 250	31.6	525	252	273	279
300 x 300	35.0	554	272	282	278

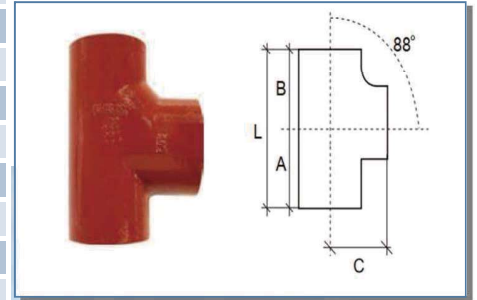



YU KUNYU BS EN877 EPOXY CAST IRON PIPES & FITTINGS FOR DRAINAGE SYSTEM

88° INSPECTION BRANCH

Nominal Size(mm)	kg/pcs	L(mm)	A(mm)	B(mm)	C(mm)
50 x 50	1.3	146	80	81	66
75 x 50	5.0	183	96	91	87
75 x 75	2.9	222	131	131	91
100 x 50	3.8	205	105	96	100
100 x 75	3.8	204	112	112	92
100 x 100	4.5	276	171	153	105
150 x 100	7.5	278	163	165	115
150 x 150	11.0	353	205	192	148
200 x 100	10.5	313	167	177	146
200 x 150	11.6	343	177	187	166
200 x 200	14.3	379	197	204	182
250 x 150	34.6	440	227	226	213
250 x 200	26.5	448	231	235	217
250 x 250	31.0	473	243	246	230
300 x 200	33.6	465	240	265	225
300 x 300	43.5	549	283	283	266

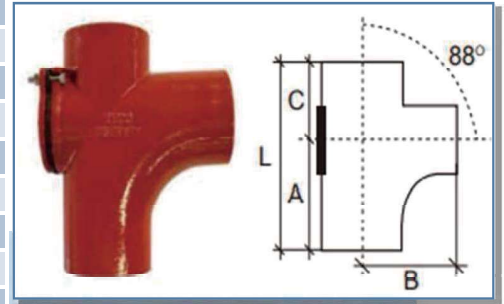

STACK SUPPORT PIPE

Nominal Size(mm)	kg/pcs.	L(mm)	D(mm)
50	1.3	200	87
75	1.6	220	118
100	2.3	200	145
150	4.0	200	195
200	6.0	200	245
250	12.5	300	340
300	24.0	350	430

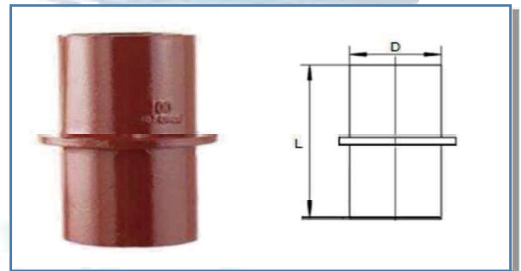

REDUCER (ECCENTRIC)

Nominal Size(mm)	kg/pcs.	A(mm)	L(mm)
75 x 50	0.5	13	80
100 x 50	0.9	25	80
100 x 75	1.1	14	90
150 x 50	2.0	51	103
150 x 75	2.2	39	101
150 x 100	2.2	25	106
200 x 100	4.1	50	116
200 x 150	4.3	25	126
250 x 100	6.2	82	128
250 x 150	6.8	57	132
250 x 200	7.0	32	146
300 x 150	10.7	84	152
300 x 200	11.4	59	162
300 x 250	12.4	26	170

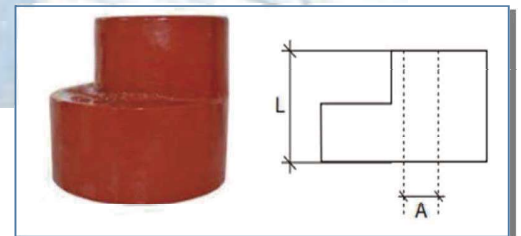



YU KUNYU BS EN877 EPOXY CAST IRON PIPES & FITTINGS FOR DRAINAGE SYSTEM

ANTI-SIPHON TRAP WITH DOOR

Nominal Size(mm)	kg/pcs.	H(mm)	L(mm)	R
50	3	251	190	80
75	7	294	265	86
100	12	450	325	85
150	35	620	470	85
200	54	742	503	85

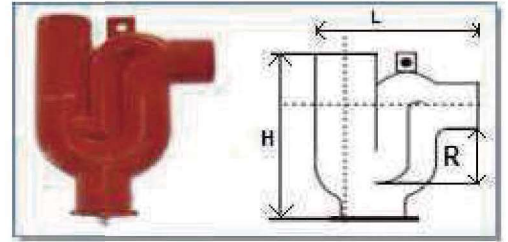

TRAP (SIPHON)

Nominal Size(mm)	kg/pcs.	L(mm)	H(mm)	X(mm)
50	3.3	190	250	182
75	7.0	290	285	190
100	11.5	325	392	282
150	35.0	470	493	348

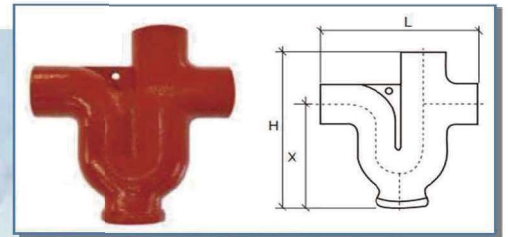

Short pipe with Round Door

Nominal Size(mm)	kg/pcs.	L(mm)
75	3.1	220
200	18	465

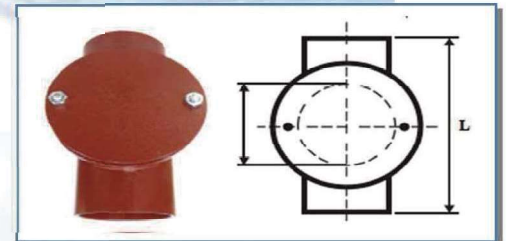

Anti-Syphonage Trap With Branch (Plug or Access Door)

Nominal Size(mm)	L(mm)	H(mm)
50	150	219

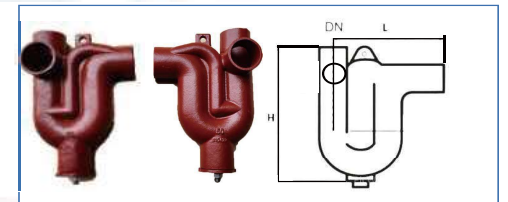

Short pipe with Square Door

Nominal Size(mm)	kg/pcs.	L(mm)	H(mm)
75	3.4	300	50
100	7.6	340	60
150	14.5	395	85
200	22	465	110
250	35	570	150
300	51	640	190



CAP

Nominal Size(mm)	kg/pcs.	L(mm)
50	0.2	30
75	0.5	35
100	0.7	44
150	1.7	50
200	3.1	56
250	6.0	70
300	9.5	80

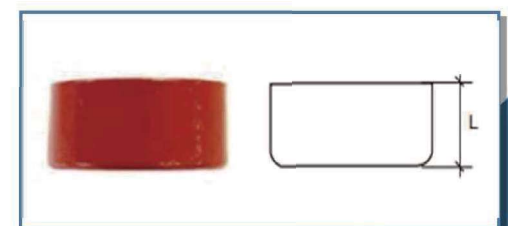



YU KUNYU BS EN877 EPOXY CAST IRON PIPES & FITTINGS FOR DRAINAGE SYSTEM

Coupling

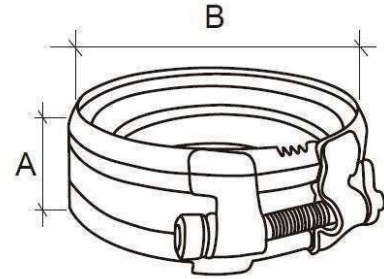

Type 'B' - SS316 Stainless Steel Coupling

Nominal Size(mm)	A(mm)	B(mm)
50	43	71
75	47	98
100	47	124
150	55	180
200	68	230

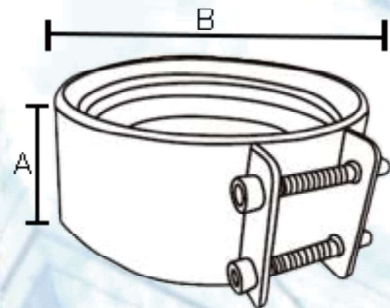

Type 'CHA' - SS316 Stainless Steel Coupling

Nominal Size(mm)	A(mm)	B(mm)
50	58	71
75	58	96
100	58	123
150	71	173
200	83	223
250	140	287
300	140	339



YU KUNYU BS EN877 EPOXY CAST IRON PIPES & FITTINGS FOR DRAINAGE SYSTEM

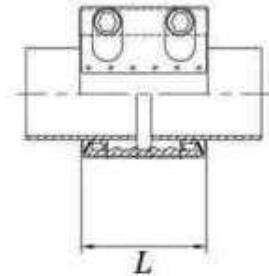
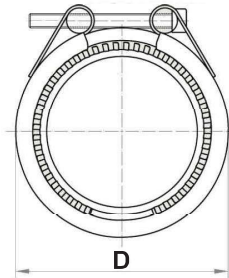

SS316 Stainless Steel MJG Coupling (High Pressure)		
Nominal Size(mm)	L(mm)	D(mm)
50	80	76
75	110	110
100	110	135
150	110	287
200	150	243
250	150	294
300	150	345

Grip Collar

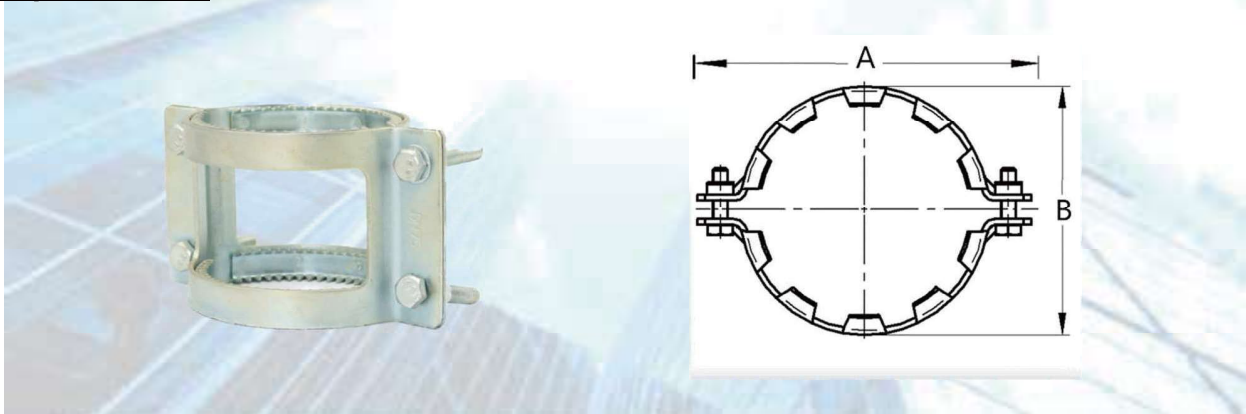

Grip Collar / Clamp		
Nominal Size(mm)	A(mm)	B(mm)
75	185	95
100	215	95
150	270	100
200	317	135
250	390	160
300	455	190



YU KUNYU BS EN877 EPOXY CAST IRON PIPES & FITTINGS FOR DRAINAGE SYSTEM

Recommendations On Jointing, Handling ETC.

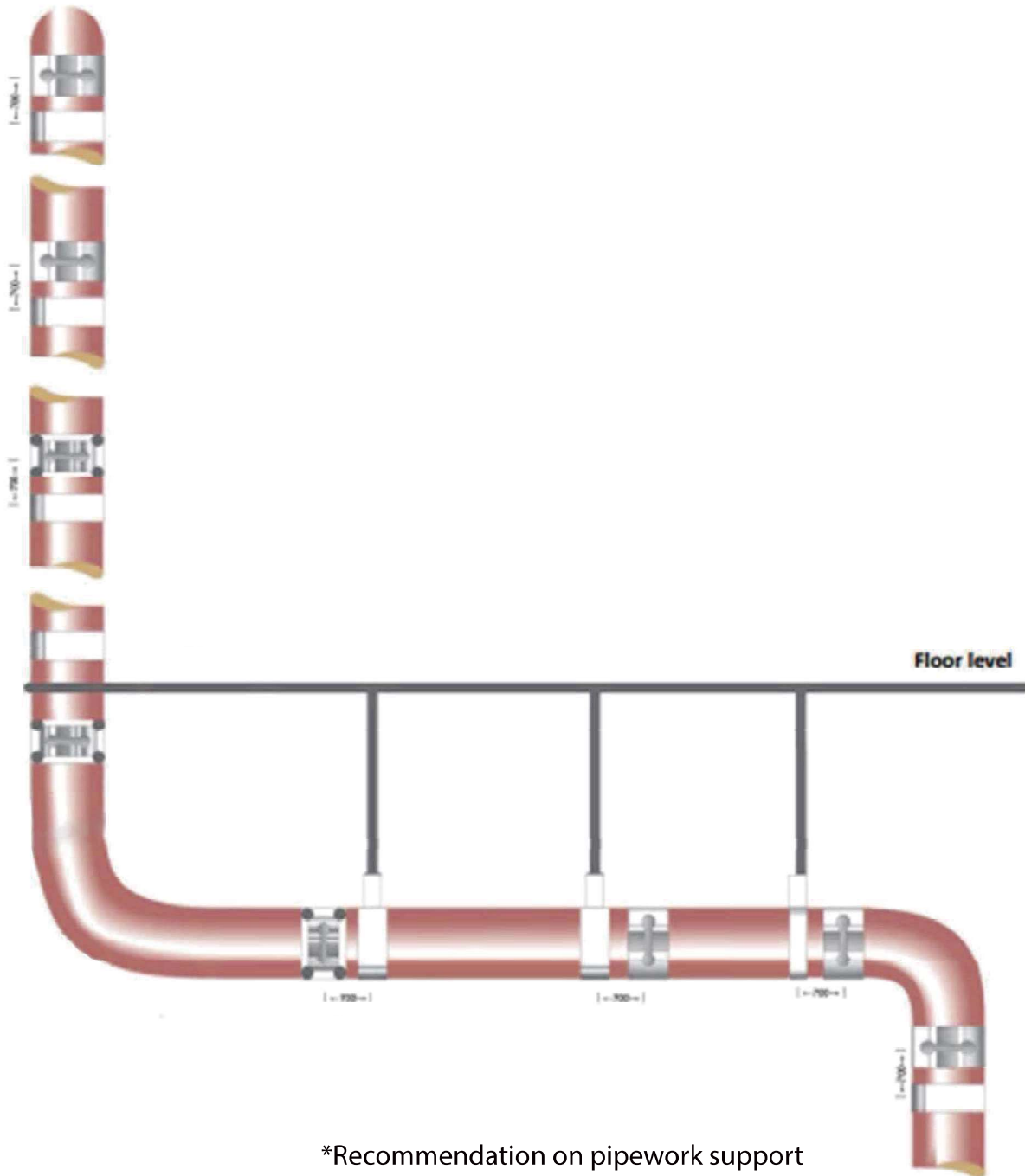

*Recommendation on pipework support



YU KUNYU BS EN877 EPOXY CAST IRON PIPES & FITTINGS FOR DRAINAGE SYSTEM

Recommendations On Jointing, Handling ETC.

Recommendation on jointing Method by Mechanical Metal Cooling

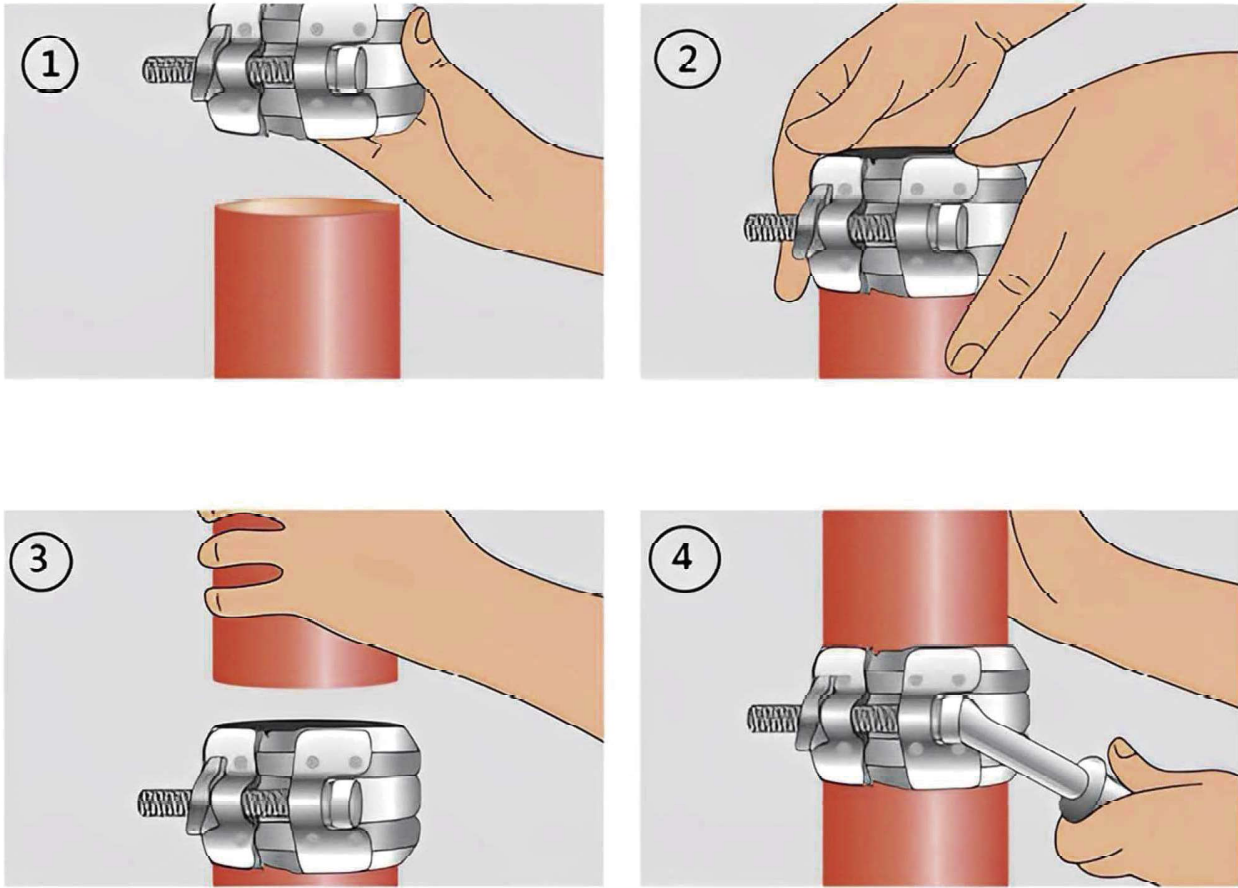

Step 1. Take a pipe and cut it to the desired length at right angles to the axis using an electric cutter, following site safety guidelines. Carefully polish the cut end of the pipe and apply epoxy touch-up paint to the cut area as recommended.

Step 2. Slide the coupling (consisting of EPDM gasket inside and stainless steel mounting collar outside) onto the end of the pipe or connection spigot up to the center of the gasket.

Step 3. Push the next pipe or fitting into the coupling, making sure that the cut pipes are square.

Step 4. Tighten the screws of the coupling with a screwdriver, making sure that the electrical contact between the metals is ensured. The pipe can be fixed according to the given sketch and supported by brackets with support in the appropriate place.



YU KUNYU BS EN877 EPOXY CAST IRON PIPES & FITTINGS FOR DRAINAGE SYSTEM

Recommendations On Jointing, Handling ETC.

YU Epoxy touch-up paint



YU Epoxy paint is recommended to be applied to the system after pipes have been cut to suit project needs. It is a low-VOC, universal water-based epoxy amine-adduct primer in red color designed for mild to moderate industrial use, for instance, to coat incised surfaces of cast iron pipes.

For best corrosion protection, incised surfaces of cast iron pipes shall be cleaned thoroughly with burrs removed before being coated with '**YU**' epoxy touch-up paint



Outstanding Feature

- ✓ **Easy to use**
- ✓ **Epoxy Acrylic Resin**
- ✓ **Reddish Brown**
- ✓ **Anti-Corrosion**